

# HANOVER<sup>®</sup>

## Hanover Outdoor Furniture



### **IMPORTANT**

If you have any problems with this product (missing or damaged parts, assembly issues, etc.),

**PLEASE DO NOT RETURN TO THE RETAILER/STORE**

from where you purchased the product.

Please call our Toll-Free Customer Service Hotline at: **1-800-416-3511**

Between 9:00 AM and 5:00 PM Eastern Time, Monday through Friday

Or visit our website at: **[www.hanover-products.com](http://www.hanover-products.com)**

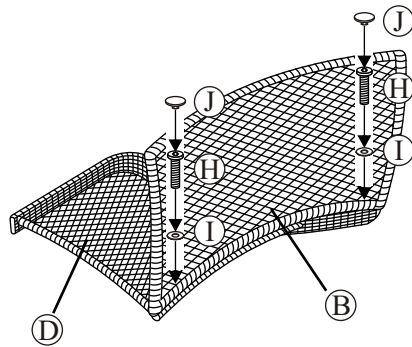
To expedite any future warranty claims, please retain the Instruction Sheet, Warranty Card and receipt for future use.

For additional on-line support on assembly, troubleshooting and care & maintenance of your outdoor furniture, please visit our website at: **[www.hanover-products.com](http://www.hanover-products.com)**.

**IMPORTANT!! PLEASE READ ENTIRE INSTRUCTION SHEET BEFORE ASSEMBLY!!  
TO EXPEDITE ANY FUTURE WARRANTY CLAIMS, PLEASE KEEP INSTRUCTION SHEET, WARRANTY CARD AND RECEIPT**

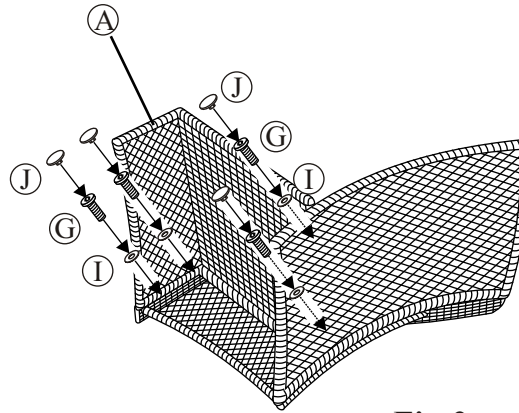
**Step 1:** Carefully unpack and identify all parts packed in the carton against the parts list. Remove all protective materials. If you are missing any parts or are unsure how to proceed with assembly, call our customer service center immediately at 1-800-416-3511. **Do not attempt to assemble glider if any parts are missing or damaged.** Assemble furniture on a smooth, non-abrasive surface.

**Step 2:** Attach the back frame to right arm by using two 5/16"x40 mm bolts and washers as shown in **Fig.1**. Guide the bolts through holes in back frame, into pre-drilled holes in the right arm. **Hand tighten only.** Attach the seat frame to right arm and back frame by using four 5/16"x25 mm bolts and washers as shown in **Fig.2**. **Hand tighten only.** Attach the left arm to back and seat frame by using two 5/16"x25 mm bolts and two 1/4"x40 mm bolts and four washers as shown in **Fig.3**. **Hand tighten only.**

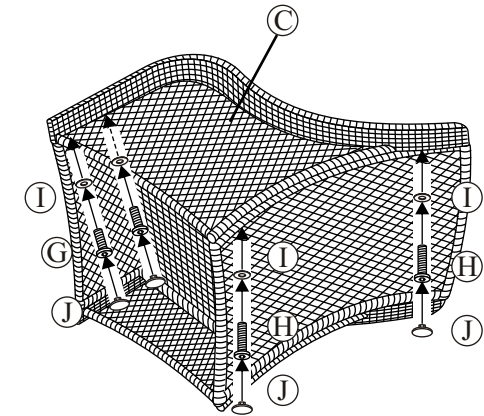


**Fig.1**

GLIDER BASE W/  
GLIDER BRACKET

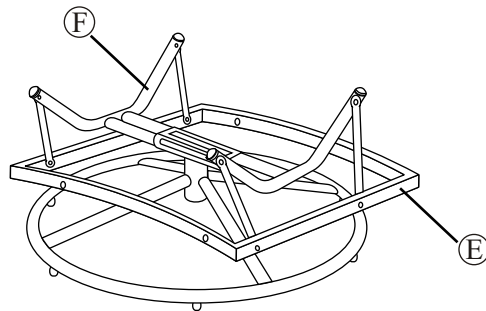


**Fig.2**

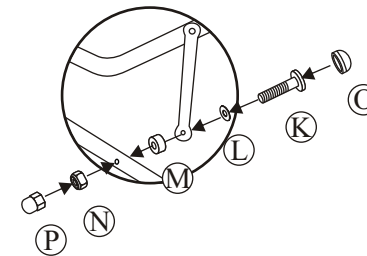


**Fig.3**

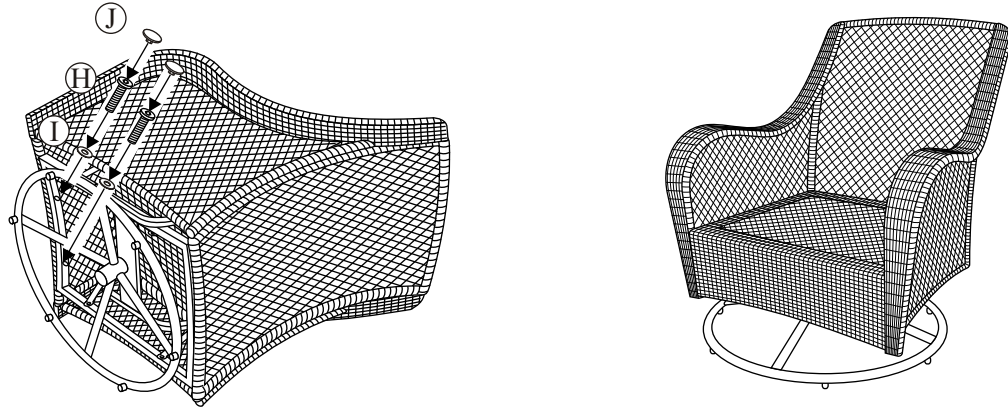
**Step 3:** Attach the support frame assembly to one side of glider base/glider. Insert two bolts exactly as shown in **Fig.4**: through Ø15x4mm washers/armrest frame/Ø15x6mm washers/glider bracket/Ø6.5x1.0mm washers/nuts. Hand tighten only as some adjustments may be needed for proper alignment or tension of the glider. Repeat on opposite side.



**Fig.4**



**Step 4:** Attach the complete base to the complete seat by using four 1/4"x45 mm bolts and washers as shown in **Fig.5**. Guide the bolts through holes in base, into the pre-drilled holes in the seat. **Hand tighten only.**



**Fig.5**

**Step 5:** Using the hex wrench and hex bolt driver provided, tighten all nuts and bolts. **Do not over tighten bolts. If nuts and bolts are too tight or too loose, the glider will not function properly.** Test the operation of glider. Gliding motion should be smooth. Adjust tension on the glider brackets, nuts and bolts as needed. Cover nuts and bolts with covers provided.

**Step 6:** With the help of another person, turn the chair in the upright position. Your chair is now ready for use. If you have any questions, please call our Customer Service Center at 1-800-416-3511.

**IMPORTANT NOTE:** Damage to welds or frames resulting from over tightened bolts or improper assembly is not covered under our warranty. Please read all instructions carefully before assembly. If you have any questions regarding your assembly, call our Customer Service Center at 1-800-416-3511.

\* NOTE: PARTS SHOWN BELOW ARE NOT TO SCALE

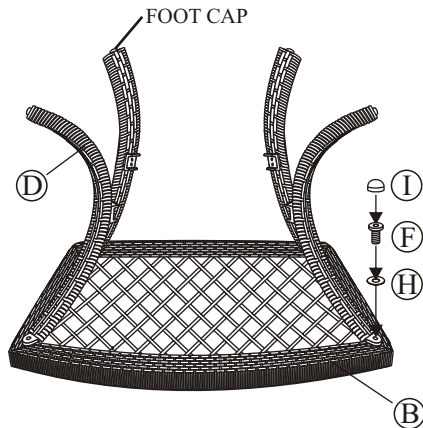
	PARTS LIST	DESCRIPTION	ORDER PART #	QTY
A		SEAT FRAME	SG0154	1
B		BACK FRAME	SG0155	1
C		LEFT ARM	SG0156	1
D		RIGHT ARM	SG0157	1
E		SUPPORT FRAME	SG0158	1
F		GLIDER BASE W/ GLIDER BRACKET	SG0159	1
G		5/16" X 25 MM BOLT	HW0186	6
H		5/16" X 40 MM BOLT	HW0275	8
I		Ø8.5 X 1.5 MM WASHER	HW0005	14
J		BOLT COVER-1	HW0105	14
K		1/4" X 45 MM BOLT	HW0040	4
L		Ø6.5 X 1.0 MM WASHER	HW0004	4
M		Ø6.5 X 6 MM WASHER	HW0138	4
N		1/4" NUT	HW0014	4
O		BOLT COVER-2	HW0105	4
P		NUT COVER	HW0027	4
Q		HEX BOLT DRIVER	HW0006	1
R		HEX WRENCH	HW0009	1
		GLIDER BRACKET FACTORY ASSEMBLY	G0080	
		ST4.8 X 25 BOLT FACTORY ASSEMBLY	HW0695	
		FOOT CAP FACTORY ASSEMBLY	FC0013	

**BGS12023**

**IMPORTANT!! PLEASE READ ENTIRE INSTRUCTION SHEET BEFORE ASSEMBLY!!  
TO EXPEDITE WARRANTY CLAIMS PLEASE KEEP INSTRUCTION SHEET, WARRANTY CARD AND COPY OF RECEIPT**

**Step 1:** Carefully remove glass and set aside until Step 5. Lay glass flat--do not stand glass on edge. Remove all protective materials and set parts on a flat, non-abrasive surface. Identify parts packed in carton against the parts list. If you are missing any parts or are unsure how to proceed with assembly, call our Customer Service Center at 1-800-416-3511. **Do not attempt assembly if any parts are missing or damaged.**

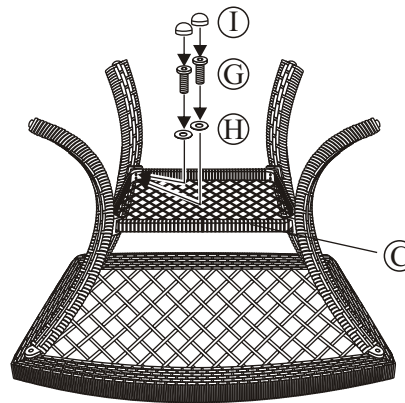
**Step 2:** Place the table rim (without glass) upside down on a flat, non-abrasive surface. Attach a table leg to the rim by using a 1/4"x20 mm bolt and a washer as shown in **Figure 1**. Guide the bolt through the hole in the table leg, into the pre-drilled hole in the table rim. **Hand tighten bolt 3-4 revolutions only. Do not tighten completely.** Some adjustments may be necessary to ensure proper alignment of the table legs. Repeat for the other three table legs.



*Figure 1*

**BPC02101**

**Step 3: Build the leg assembly.** Attach the legs to the leg connector bracket by using the 1/4"x35 mm bolts as shown in **Figure 2**. Add a washer to each bolt. Guide these bolts through the holes in the leg connector bracket, and into the fixed nuts already in place in the legs. Do not over-tighten. Only 3-4 turns to ensure the leg stays in position. Repeat this procedure on the other three legs.














*Figure 2*

**Step 4:** After making any necessary adjustments to the alignment of the table legs and the leg connector bracket, use hex bolt driver to tighten all bolts. **Note:** Each bolt must be tightened a few revolutions at a time. In order to apply equal pressure to all bolt joints, we recommend working in a cross corner (X fashion). Repeat until all bolts are tight. **Do not over tighten.** Over tightening may strip bolts or damage the welds or frame. Cover all bolts with covers.

**Step 5:** With the help of another person, turn the table in the upright position. Note the clear bumpers spaced evenly throughout the inside of the rim. Carefully place glass inside the rim, resting on the clear bumpers. Your table is now ready for use. If you have any questions, please call our Customer Service Center at 1-800-416-3511.

**IMPORTANT NOTE: Damage to welds or frames resulting from over tightened bolts or improper assembly is not covered under our warranty. Please read all instructions carefully before assembly. If you have any questions regarding your assembly, call our Customer Service Center at 1-800-416-3511.**

*\* NOTE: PARTS SHOWN ON PARTS LIST ARE NOT TO SCALE*

	<u>PARTS LIST</u>	<u>DESCRIPTION</u>	<u>ORDER PART #</u>	<u>QTY</u>
A		GLASS TOP		1
B		TABLE RIM	ST1613	1
C		LEG CONNECTOR BRACKET	ST1614	1
D		TABLE LEG	ST1615	4
E		HEX BOLT DRIVER	HW0006	1
F		1/4" X 20 MM BOLT	HW0036	4
G		1/4" X 35 MM BOLT	HW0142	8
H		Ø6.5 X 1.0 MM WASHER	HW0004	12
I		BOLT COVER	HW0105	12
		BUMPER FACTORY ASSEMBLY	G0002	
		FOOT CAP FACTORY ASSEMBLY	FC0069	